

## S-BM2

Smoke Control Damper - MA Multi

Data Sheet



# Table of Contents

Description . . . . .	3
Design . . . . .	4
Fire Resistivity . . . . .	6
Dimensions. . . . .	8
Installation Distances . . . . .	8
Dimensions . . . . .	9
Free Area. . . . .	10
Ordering Code . . . . .	11
Accessory . . . . .	12
Technical Parameters . . . . .	14
Installation, Maintenance & Operation . . . . .	17
Transport & Storage . . . . .	17
Supplement . . . . .	17
Related Products. . . . .	18



## Good to know

Current information on all products is available at [www.design.systemair.com](http://www.design.systemair.com)



## Description

Smoke control dampers are designed for mechanical or natural smoke and heat extraction systems. Its function is to extract toxic gases, smoke and fire or provide a supply of fresh air to fire compartments. Smoke control dampers are fitted with an actuator without a spring; therefore, they have two safety positions, "open" and "closed" and require power even in the event of fire.

S-BM2 smoke control damper is designed for the installations listed in the "Fire resistivity" section of this document.

### Highlights

- Nominal sizes (mm) 200 × 425 up to 1000 × 1225
- Certified according to EN 12101-8
- MA – manual intervention (can be used also as an AA classified smoke control damper)
- The safety position can be adjusted up to first 25 minutes during smoke extraction
- Multi – usage in compartments classified as the "multi"
- Pressure level 2 (-1000 Pa up to 300 Pa)
- Casing leakage according to EN 1751, class C
- Blade leakage according to EN 1751, class 3
- Exceptional free area and low pressure drop
- Installed into walls or ducts

### Accessory

- K1-S-BM2: Cover Boards for In-Duct Installation

# Design

S-BM2 has a casing and blades made from calcium silicate board. The closed damper is sealed by silicate wool sealing to avoid the spread of heat and smoke.

Front board surfaces are fitted with threaded inserts for sheet metal duct flanges. If the damper is ordered with grille, both sides are fitted with threaded inserts for grille placement. S-BM2 has mechanism and actuator enclosed by the dampers casing and two covers on each side for easy access and connection.

## Material Composition

The product contains galvanized sheet metal, calcium silicate board, fireproof carbon fiberglass, polyurethane foam and alkaline earth silicate wool. These are processed in accordance with local regulations. The product contains no hazardous substances.

## Tightness of the Blade and the Casing

S-BM2 smoke control damper, as standard, have class C casing tightness and class 3 blade tightness according to EN 1751.

## Product Parts

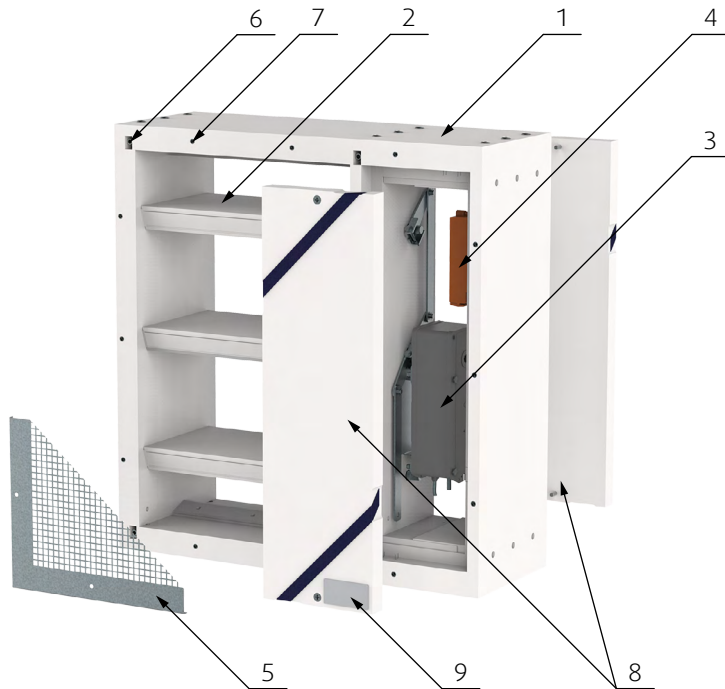

### Legend

1	Damper casing
2	Damper blade
3	Actuator
4	Supply and communication unit (BST)
5	Sheet metal grille
6	Threaded inserts for duct connection
7	Threaded inserts for the grille
8	Mechanism cover
9	Product label

Fig. 1: Components of S-BM2











## Activation Types

- **B230**  
Smoke control damper fitted with a Belimo actuator (AC 230 V) with auxiliary switches.
- **B24**  
Smoke control damper fitted with a Belimo actuator (AC/DC 24 V) with auxiliary switches.
- **BST**  
Smoke damper fitted with a Belimo actuator with auxiliary switches, with a Belimo supply and a BKNE230-24 communication unit (communication unit supply: AC 230 V). The actuator (AC/DC 24 V) is powered from the communication unit. Other communication units are available upon request.













# Fire Resistivity

S-BM2 Smoke control dampers are CE certified following the Construction Products Regulation according to EN 12101-8:2011. Tested according to EN 1366-10:2011 + A1:2017, EN 1366-2:2015 and classified according to EN 13501-4:2016. The smoke control damper together with its installation form an inseparable part of the fire resistivity rating.









Tab. 1: Fire resistivity of S-BM2 - wall mounted

Dimension Range (mm)	Classification	Supporting Construction	Construction Type/Minimal Thickness (mm)			Allowed Blade Axis Orientation	
			 1 Wet	 2 Dry	 3F Fit		
200 × 425 up to 1000 × 1225	EI90 (v <sub>ew</sub> i ↔ o) S1000 C <sub>mod</sub> MAmulti	Wall	Rigid/125 Flexible/125				
	EI90 (h <sub>ow</sub> i ↔ o) S1000 C <sub>mod</sub> MAmulti	Floor/ceiling	-				
	EI120 (v <sub>ew</sub> i ↔ o) S1000 C <sub>mod</sub> MAmulti	Wall	Rigid/125 Flexible/125				
	EI120 (h <sub>ow</sub> i ↔ o) S1000 C <sub>mod</sub> MAmulti	Floor/ceiling	-				

Tab. 2: Fire resistivity of S-BM2 - duct mounted

Dimension Range (mm)	Classification	Duct Orientation	Applicable Duct Tested per Standard				Allowed Blade Axis Orientation		
			 DBH DMR In the Duct	 D1H D2H On the Duct/ Bottom Mounted	 D1H D2H On the Duct/ Top Mounted	 D1H D2H D1V D2V On the Duct/ Side Mounted			
200 × 425 up to 1000 × 1225	EI90 (v <sub>ed</sub> i ↔ o) S1000 C <sub>mod</sub> MAmulti	Horizontal duct	EN 1366-9, EN 1366-8	EN 1366-9, EN 1366-8					
	EI90 (h <sub>od</sub> i ↔ o) S1000 C <sub>mod</sub> MAmulti	Vertical duct	-						
	EI120 (v <sub>ed</sub> i ↔ o) S1000 C <sub>mod</sub> MAmulti	Horizontal duct	EN 1366-9, EN 1366-8						
	EI120 (h <sub>od</sub> i ↔ o) S1000 C <sub>mod</sub> MAmulti	Vertical duct	-						

## Legend

	① Wet Installation
	② Dry Installation
	③ Fit Installation
	Damper placed on duct surface, bottom side of the duct
	Damper placed on duct surface, top side of the duct
	Damper placed on duct surface, left and right side of the duct
	Damper placed within the duct canal, outside of supporting construction
<b>DBH</b>	Installation in the duct made of promatect boards
<b>DMH</b>	Installation in the duct made of sheet metal
<b>D1H</b>	Installation on the horizontal duct - flush with edges
<b>D2H</b>	Installation on the horizontal duct - surface
<b>D1V</b>	Installation on the vertical duct - flush with edges
<b>D2V</b>	Installation on the vertical duct - surface
	Horizontal blade axis orientation of the damper
	Vertical blade axis orientation of the damper

# Dimensions

## Installation Distances

According to the EN 1366-2 standard, the minimum distance from the wall or ceiling to the damper body is 75 mm. For multiple crossings through fire resistant wall, the minimum distance between two damper bodies is 200 mm. This applies for distances between the damper body and a nearby foreign object crossing the fire-resistant wall. Damper clearances vary according to the type of mechanism and their rotation.

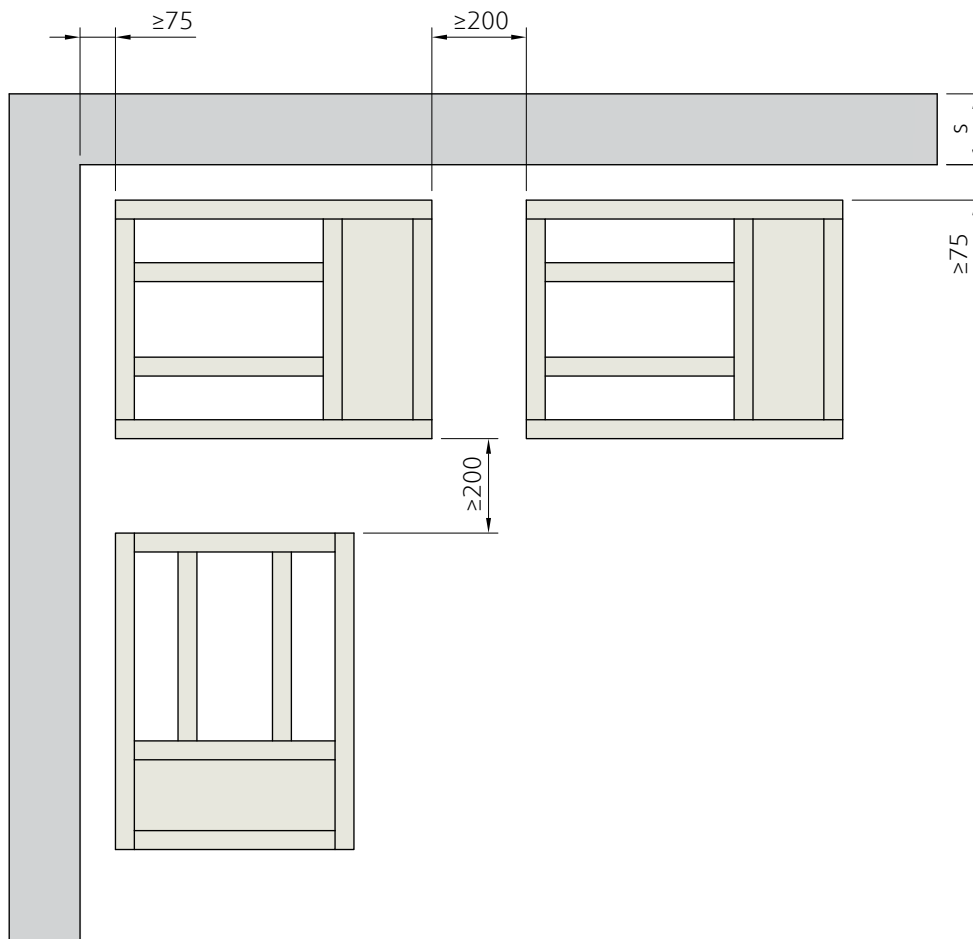
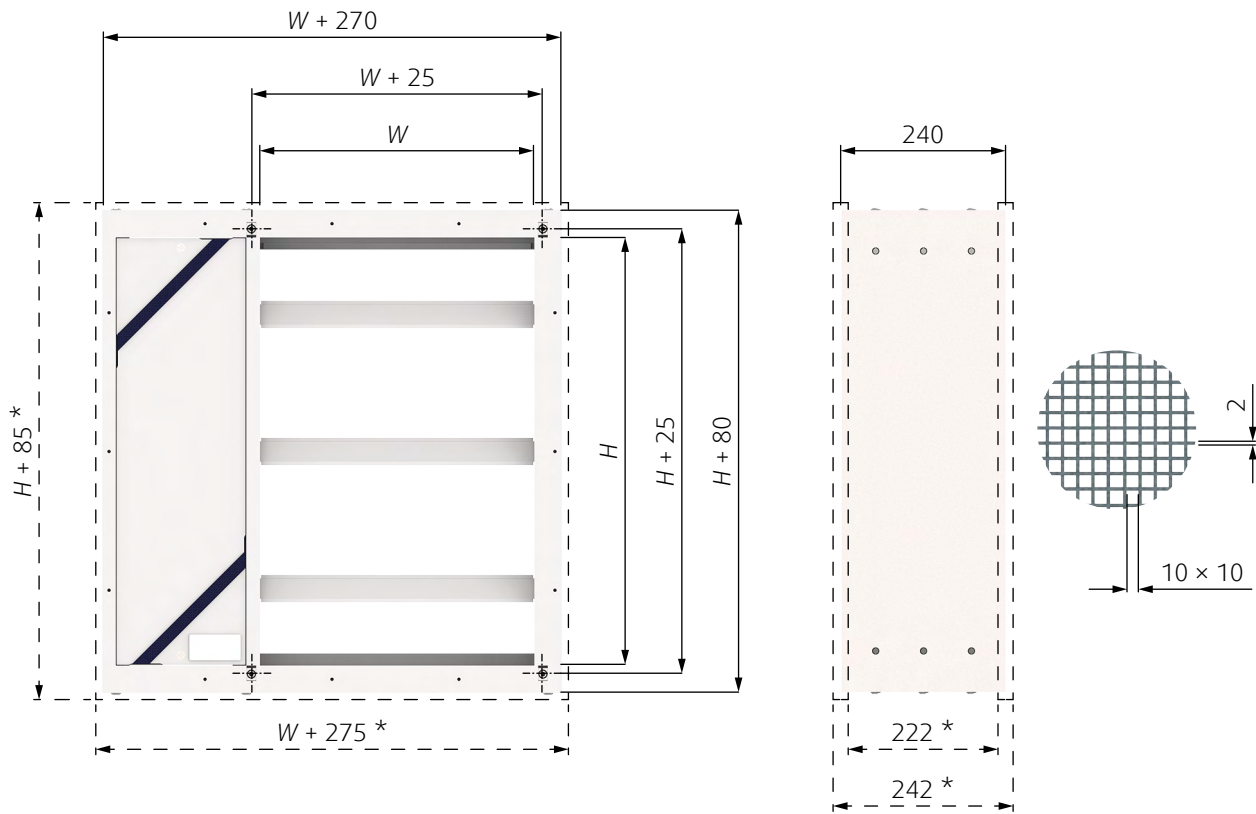

Fig. 2: Installation distances between damper bodies



### Dimensions

The damper blades are in the open position within the damper housing.



Tab. 3: Dimensions of S-BM2 and grille

NOTE: \* - grille dimensions

Tab. 4: Weight of S-BM2

S-BM2 WITHOUT GRILLE	m (kg)	W (mm)																
		200	250	300	350	400	450	500	550	600	650	700	750	800	850	900	950	1000
	H (mm)	425	26,9	28,3	29,6	31,0	32,3	33,7	35,0	36,4	37,7	39,1	40,4	41,8	43,1	44,5	45,8	47,2
625	34,5	36,1	37,8	39,4	41,1	42,7	44,4	46,0	47,7	49,3	50,9	52,6	54,2	55,9	57,5	59,2	60,8	
825	42,1	44,0	45,9	47,9	49,8	51,8	53,7	55,7	57,6	59,6	61,5	63,5	65,4	67,3	69,3	71,2	73,2	
1025	50,6	52,9	55,1	57,4	59,6	61,8	64,1	66,3	68,6	70,8	73,0	75,3	77,5	79,8	83,0	85,3	87,5	
1225	58,2	60,8	63,3	65,9	68,4	70,9	73,5	76,0	78,6	81,1	83,6	87,2	89,7	92,3	94,8	97,4	99,9	

S-BM2 WITH ONE GRILLE	m (kg)	W (mm)																
		200	250	300	350	400	450	500	550	600	650	700	750	800	850	900	950	1000
	H (mm)	425	28,4	29,8	31,3	32,8	34,2	35,7	37,1	38,6	40,1	41,5	43,0	44,4	45,9	47,4	48,8	50,3
625	36,4	38,1	39,9	41,7	43,5	45,3	47,1	48,9	50,6	52,4	54,2	56,0	57,8	59,6	61,3	63,1	64,9	
825	44,4	46,5	48,6	50,7	52,8	54,9	57,0	59,1	61,2	63,3	65,4	67,5	69,6	71,7	73,8	75,9	78,1	
1025	53,4	55,8	58,2	60,7	63,1	65,5	67,9	70,4	72,8	75,2	77,6	80,1	82,5	84,9	88,4	90,8	93,2	
1225	61,4	64,1	66,9	69,7	72,4	75,1	77,9	80,7	83,4	86,2	88,9	92,7	95,4	98,2	100,9	103,7	106,4	

S-BM2 WITH TWO GRILLES	m (kg)	W (mm)																
		200	250	300	350	400	450	500	550	600	650	700	750	800	850	900	950	1000
	H (mm)	425	29,9	31,4	33,0	34,6	36,1	37,7	39,3	40,9	42,4	44,0	45,6	47,1	48,7	50,3	51,9	53,4
625	38,3	40,2	42,1	44,0	46,0	47,9	49,8	51,7	53,6	55,5	57,4	59,4	61,3	63,2	65,1	67,0	69,0	
825	46,7	49,0	51,2	53,5	55,8	58,0	60,3	62,6	64,8	67,1	69,3	71,6	73,9	76,1	78,4	80,7	82,9	
1025	56,1	58,7	61,3	64,0	66,6	69,2	71,8	74,4	77,0	79,6	82,2	84,9	87,5	90,1	93,7	96,3	98,9	
1225	64,6	67,5	70,5	73,5	76,4	79,4	82,3	85,3	88,3	91,2	94,1	98,1	101,1	104,1	107,0	110,0	112,9	

### Free Area

Tab. 5: Free area of the S-BM2

S-BM2 WITHOUT GRILLE	A <sub>v</sub> (m <sup>2</sup> )	W (mm)																
		200	250	300	350	400	450	500	550	600	650	700	750	800	850	900	950	1000
	H (mm)	425	0,07	0,08	0,10	0,11	0,13	0,15	0,16	0,18	0,20	0,21	0,23	0,25	0,26	0,28	0,29	0,31
625	0,10	0,12	0,15	0,17	0,19	0,22	0,24	0,27	0,29	0,32	0,34	0,37	0,39	0,41	0,44	0,46	0,49	
825	0,13	0,16	0,19	0,23	0,26	0,29	0,32	0,36	0,39	0,42	0,45	0,49	0,52	0,55	0,58	0,61	0,65	
1025	0,16	0,20	0,24	0,28	0,32	0,36	0,40	0,44	0,48	0,52	0,56	0,61	0,65	0,69	0,73	0,77	0,81	
1225	0,19	0,24	0,29	0,34	0,39	0,44	0,48	0,53	0,58	0,63	0,68	0,73	0,77	0,82	0,87	0,92	0,97	

S-BM2 WITHOUT GRILLE	A <sub>v</sub> (m <sup>2</sup> )	W (mm)																
		200	250	300	350	400	450	500	550	600	650	700	750	800	850	900	950	1000
	H (mm)	425	0,05	0,06	0,07	0,08	0,09	0,10	0,11	0,12	0,14	0,15	0,16	0,17	0,18	0,19	0,20	0,21
625	0,07	0,08	0,10	0,12	0,13	0,15	0,17	0,18	0,20	0,22	0,24	0,25	0,27	0,29	0,30	0,32	0,34	
825	0,09	0,11	0,13	0,16	0,18	0,20	0,22	0,25	0,27	0,29	0,31	0,33	0,36	0,38	0,40	0,42	0,45	
1025	0,11	0,14	0,17	0,19	0,22	0,25	0,28	0,31	0,33	0,36	0,39	0,42	0,45	0,47	0,50	0,53	0,56	
1225	0,13	0,17	0,20	0,23	0,27	0,30	0,33	0,37	0,40	0,43	0,47	0,50	0,53	0,57	0,60	0,63	0,67	

# Ordering Code

		S-BM2-	□	×	□	-	□	-	□
		200							
		...							
Width (mm)	Step 50	1000							
		425							
		625							
		825							
		1025							
Height (mm)		1225							
	No grille <sup>1)</sup>	00							
	One side with a grille, zinc coated <sup>2)</sup>	01							
	One side with a grille, RAL 9003 <sup>2)</sup>	02							
	Both sides with a grille, zinc coated	11							
Grille *	Both sides with a grille, RAL 9003	22							
	230 V	B230							
	24 V	B24							
Activation Type	24 V + communication unit BKNE (230 V)	BST							

## NOTES:

1) Not possible to connect the grille to the damper (duct installed)

2) Grille is re-mountable to each side of the damper.

## Example of the Ordering Code

S-BM2-800×625-02-BST

Multi-compartment rectangular smoke control damper, classified as a manual intervention type.

With dimensions width  $W = 800$  mm and height  $H = 625$  mm.

Assembled with one powder coated grille in RAL9003 as standard.

Outfitted with Belimo actuator (AC/DC 24 V) with auxiliary switches and with supply and communication unit BKNE230-24 (AC 230 V).

# Accessory

## K1-S-BM2

Cover Boards for In-Duct Installation



### Description

This S-BM2 accessory must be used when the smoke damper is installed within a continuous duct. Its main purpose is to cover the damper for a resistivity 120 minutes of the mineral wool and create a heat resistant connection.

### Design

Over boards are made of calcium silicate Masterboard ( $1000 \text{ kg/m}^3$ ) with a thickness 9 mm and length 240 mm produced by Promat. Self-tapping screws 5,5×30 DIN7982 for installation are included in the package.

This accessory can be replaced by boards made on-site using the same material with equal or higher density and thickness on the construction site. The positions of screws are not pre-drilled; therefore, make sure to fix the screws with a maximum spacing of 200 mm.

### Dimensions

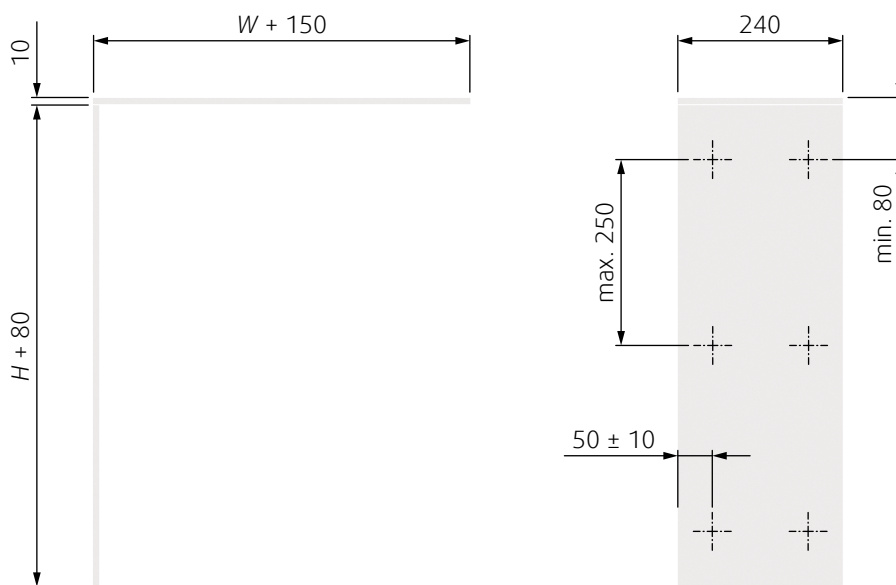

Fig. 3: Dimensions of the K1-S-BM2 accessory with the position of fixing screws

## Weights

Tab. 6: Weight of the K1-S-BM2 accessory

m (kg)		W (mm)																
		200	250	300	350	400	450	500	550	600	650	700	750	800	850	900	950	1000
H (mm)	425	2,9	3,1	3,4	3,6	3,9	4,1	4,3	4,6	4,8	5,1	5,3	5,5	5,8	6,0	6,3	6,5	6,7
	625	3,4	3,6	3,9	4,1	4,3	4,6	4,8	5,1	5,3	5,5	5,8	6,0	6,3	6,5	6,7	7,0	7,2
	825	3,9	4,1	4,3	4,6	4,8	5,1	5,3	5,5	5,8	6,0	6,3	6,5	6,7	7,0	7,2	7,5	7,7
	1025	4,3	4,6	4,8	5,1	5,3	5,5	5,8	6,0	6,3	6,5	6,7	7,0	7,2	7,5	7,7	7,9	8,2
	1225	4,8	5,1	5,3	5,5	5,8	6,0	6,3	6,5	6,7	7,0	7,2	7,5	7,7	7,9	8,2	8,4	8,7

## Ordering Code

		K1-S-BM2-	<input type="text"/>	×	<input type="text"/>
			200		
			...		
Width (mm)	Step 50		1000		
			425		
			625		
			825		
			1025		
Height (mm)			1225		

## Example of the Ordering Code

K1-S-BM2-800×625

Cover boards for in duct installation of S-BM2 smoke control damper.  
 With damper dimensions: width  $W = 800$  mm and height  $H = 625$  mm.

# Technical Parameters

Durability Test	10000 cycles, actuator controlled (0 ... 90 degrees rotation) – with no change of the required properties
	10000 cycles, actuator controlled for "MOD" classification (45 ... 60 degrees rotation) - with no change of the required properties
Testing Pressure	Underpressure up to 300 Pa, overpressure up to 1000 Pa
Safe Position	Open or Closed
Possible Installations	Vertically supported construction, rigid/flexible wall, wet/dry/soft-cross (see classification table on the page 6)
Airflow Direction	Both directions
Allowed Air Velocity	Max. 12 m/s
Side with Fire Protection	Depending on installation classification: From both sides (i <-> o)
Repeated Opening	Suitable for daily check procedure in suitable environment
Closing/Opening Time	< 60 s
Indicator Closed/Open	Indication with microswitches that are part of mechanism actuator
Environment Suitability	Only indoor environment, $T > 0$ °C and $R_{ha} < 95\%$ (3K5 according to EN 60721-3-3)
Inspection Possibility	Through grille. Inspection door for connection and actuator access. Duct inspection opening/lid where needed is not part of damper or delivery.
Maintenance	Not required/dry cleaning if demanded by law in the country in which the dampers are installed
Revisions	Determined by law in the country in which the dampers are installed, but minimally every 3 months
Allowed Pressure	1000 Pa
Blade Tightness (STN EN 1751)	Class 3 as standard
Tightness of the Housing (STN EN 1751)	Class C as standard
Conformity with EC Directives	2006/42/ES Machinery Directive
	2014/35/EU Low Voltage Directive
	2014/30/EU Electromagnetic Compatibility Directive
Driving Actuator Types	Belimo BEN24, BEN230, BEN24-ST; BEE24, BEE230, BEE24-ST; BE24, BE230, BE24-ST; BLE24, BLE230, BLE24-ST

## Legend (for Diagram 1 up to Diagram 10)

$p_s$	Pa	Pressure drop
$q_v$	m <sup>3</sup> /h l/s	Air flow volume
$L_{WA}$	dB(A)	A-weighted total discharged sound power level

W = 200

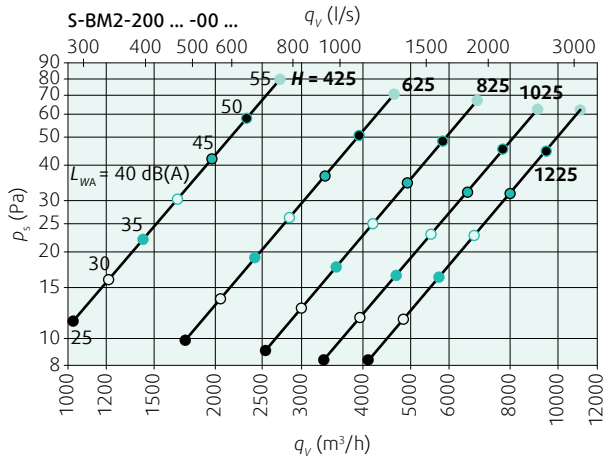

Diagram 1: Pressure drop & A-weighted total discharged sound power level depending on air flow volume at different duct pressures; measured without grille

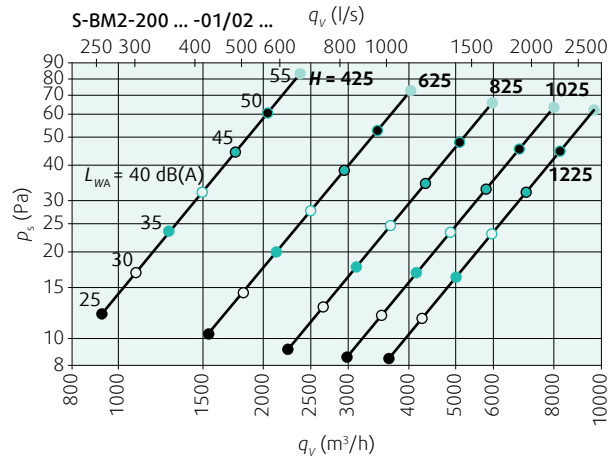

Diagram 2: Pressure drop & A-weighted total discharged sound power level depending on air flow volume at different duct pressures; measured with grille

W = 400

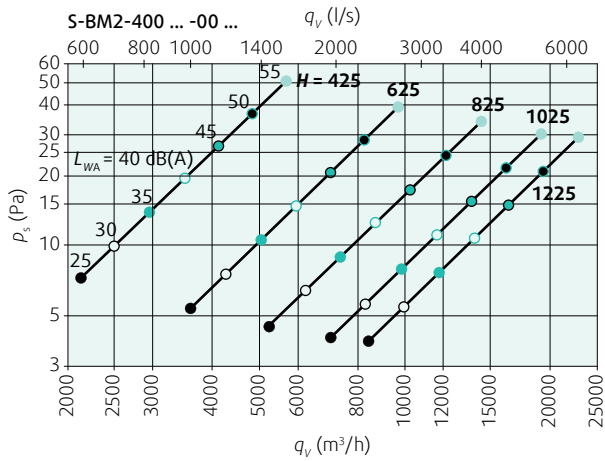

Diagram 3: Pressure drop & A-weighted total discharged sound power level depending on air flow volume at different duct pressures; measured without grille

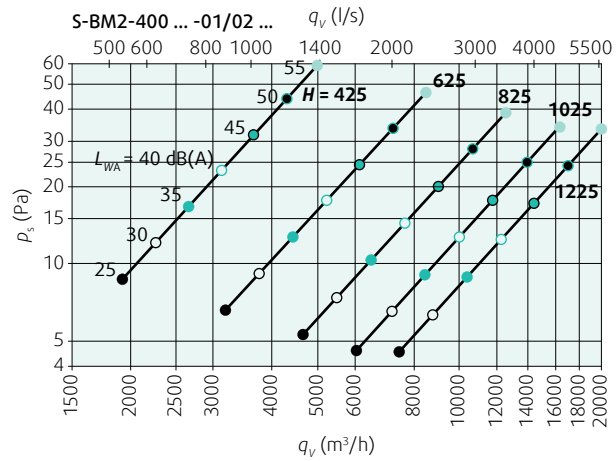

Diagram 4: Pressure drop & A-weighted total discharged sound power level depending on air flow volume at different duct pressures; measured with grille

W = 600

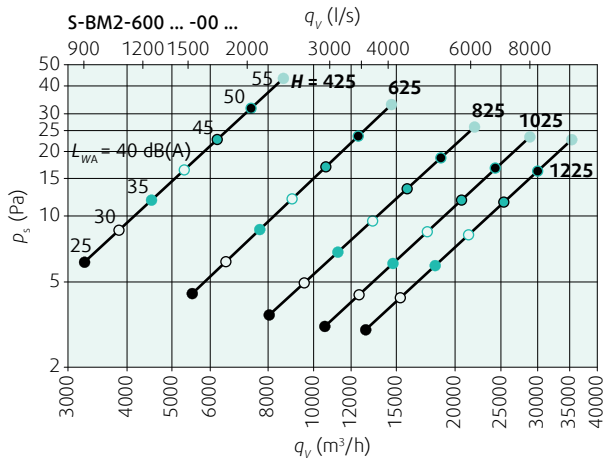

Diagram 5: Pressure drop & A-weighted total discharged sound power level depending on air flow volume at different duct pressures; measured without grille

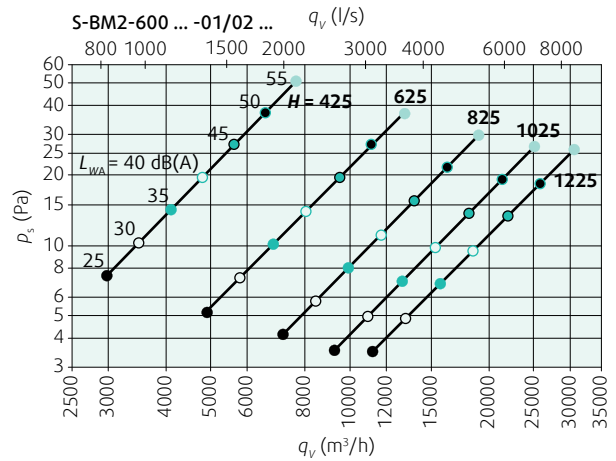

Diagram 6: Pressure drop & A-weighted total discharged sound power level depending on air flow volume at different duct pressures; measured with grille

W = 800

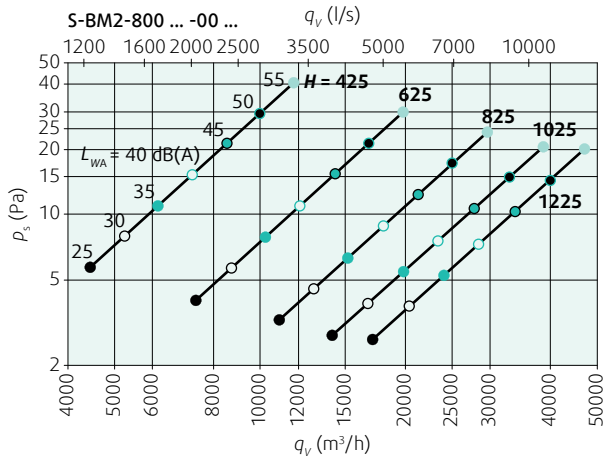

Diagram 7: Pressure drop & A-weighted total discharged sound power level depending on air flow volume at different duct pressures; measured without grille

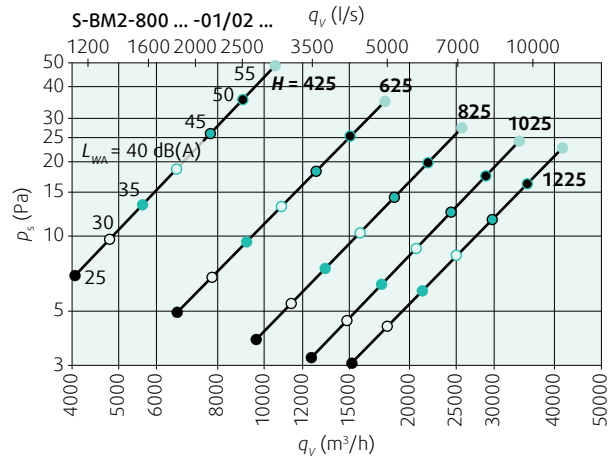

Diagram 8: Pressure drop & A-weighted total discharged sound power level depending on air flow volume at different duct pressures; measured with grille

W = 1000

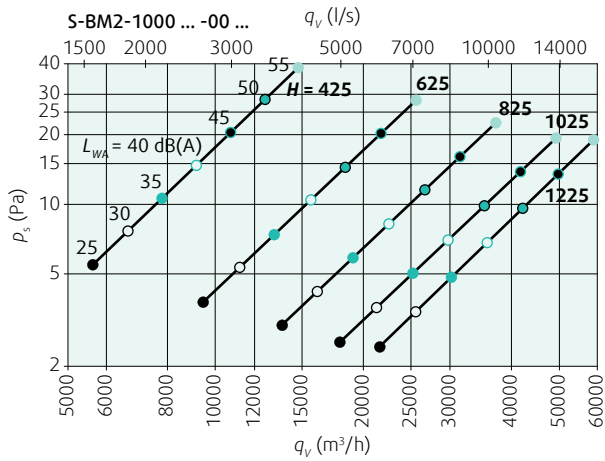

Diagram 9: Pressure drop & A-weighted total discharged sound power level depending on air flow volume at different duct pressures; measured without grille

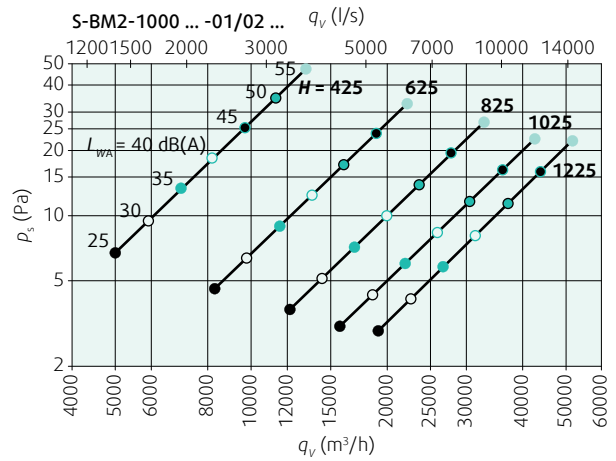

Diagram 10: Pressure drop & A-weighted total discharged sound power level depending on air flow volume at different duct pressures; measured with grille



# Installation, Maintenance & Operation

Information about installation, maintenance and operation is available in the ["UserManual\\_S-BM2"](#) document or follow the instruction on [Systemair DESIGN](#).



UserManual\_S-BM2



Systemair DESIGN

## Transport & Storage

Dry indoor conditions with a temperature range of -20°C to +40°C.

## Supplement

Any deviations from the technical specifications contained herein and the terms should be discussed with the manufacturer. We reserve the right to make any changes to the product without prior notice, provided that these changes do not affect the quality of the product and the required parameters.

Current information on all fire safety products is available at [www.systemair.com/FSPoverview](http://www.systemair.com/FSPoverview)

Current information on all products is available at [Systemair DESIGN](#).

## Related Products

### DKIR1 & DKIS1

Smoke Control Dampers - AA Single

Product information is available within the [DataSheet\\_DKIR\\_DKIS](#) technical documentation and on [Systemair DESIGN](#).



### S-SA2 & S-SA2L

Smoke Control Dampers - AA Multi

Product information is available within the [DataSheet\\_DKIR\\_DKIS](#) technical documentation and on [Systemair DESIGN](#).



